



Model PC420ATP Series - true peak Acceleration loop powered sensors (LPS™)

Output, 4-20 mA

Full scale, 20 mA (±5%).....	see table 1 on back
Frequency response:	
±10%	10 Hz - 1.0 kHz
±3 dB	4 Hz - 2 kHz
Repeatability	±2%
Transverse sensitivity, max.....	5%

Electrical

Power requirements (two wire loop power):	
Voltage at PC420 Series sensor terminals.....	10 VDC min, 30 VDC max
Loop resistance ¹ at 24 VDC, maximum	700Ω
Turn on time, 4-20 mA loop	< 30 seconds
Grounding.....	case isolated, internally shielded

Environmental

Temperature range	-40 to 85°C
Vibration limit	250 g peak
Shock limit	2,500 g peak
Sealing	hermetic

Physical

Sensing element design	PZT ceramic / shear
Weight	162 grams
Case material.....	stainless steel
Mounting	1/4 - 28 tapped hole
Output connector	2 pin, MIL-C-5015 style
Mating connector	R6 type
Recommended cabling	J9T2A

Connector pin	Function
Shell	ground
A	loop positive (+)
B	loop negative (-)

Accessories supplied: SF6 mounting stud (International customers specify mounting requirements); calibration data (level 2).

Features

- True peak output
- Corrosion resistant
- Hermetic seal
- ESD protection
- Overload protection
- Reverse wiring protection

Benefits

- 24/7 output of true peak acceleration machine vibration for trending in PLC
- True peak is useful for detecting looseness, valves, rod knock and piston slap on reciprocating machinery
- Helps guide maintenance in prioritizing need for service
- Alerts users of changing machine condition

The 4-20 mA output of the PC420ATP Series is proportional to true peak acceleration vibration. An output of 4 mA indicates a level of 0 g or no vibration present. A full-scale reading of 20 mA indicates that the maximum range of vibration is present.

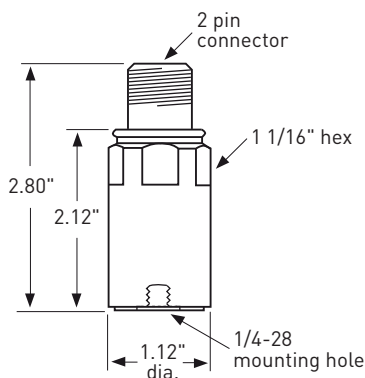

Table 1: PC420ATP-yy model number selection

yy (4-20 mA full scale)
05 = 5 g
10 = 10 g
20 = 20 g

Notes: ¹ Maximum loop resistance (R_L) can be calculated by:

$$R_L \text{ (max resistance)} = \frac{V_{\text{DC power}} - 10 \text{ V}}{20 \text{ mA}}$$

DC Supply Voltage	R_L (max resistance) ²	R_L (minimum wattage capability) ³
12 VDC	100Ω	1/8 Watt
20 VDC	500Ω	1/4 Watt
24 VDC	700Ω	1/2 Watt
26 VDC	800Ω	1/2 Watt
30 VDC	1.0kΩ	1/2 Watt

² Lower resistance is allowed, greater than 10Ω recommended.

³ Minimum R_L wattage determined by: $(0.0004 \times R_L)$.

Typical circuit

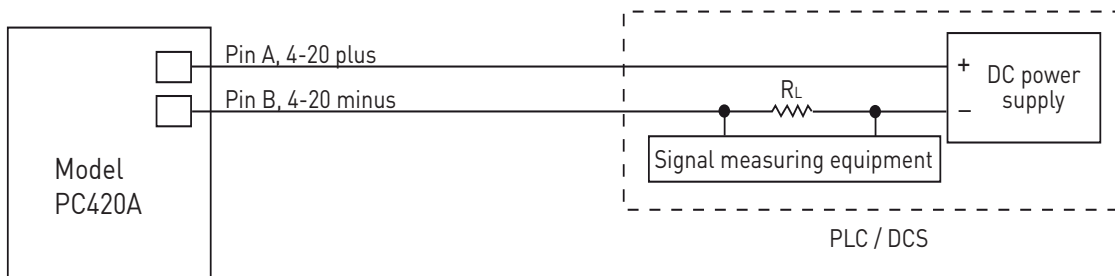

We reserve the right to vary the foregoing details without prior notice