

AAA210 / AAA220

Gravity referenced Servo Accelerometer

- Ranges $\pm 1 \text{ g}$ / $\pm 2 \text{ g}$ / $\pm 5 \text{ g}$ / $\pm 10 \text{ g}$ / $\pm 20 \text{ g}$
- Nonlinearity $\leq \pm 0.05 \%$ FRO (ranges to $\pm 10 \text{ g}$),
 $\leq \pm 0.10 \%$ FRO (range $\pm 20 \text{ g}$)
- Input voltage $\pm 15 \text{ VDC}$
- Output $\pm 5 \text{ VDC}$



The AAA210 and AAA220 Series of Servo Accelerometers measure vector acceleration with high accuracy using a closed loop force balance torquer mechanism. Typical applications include data acquisition systems, crash recorders, fatigue life monitoring and prediction; for stabilising platforms on space and ship borne satellite tracking systems; monitoring and controlling deceleration in mass transit systems; road bed analysis and fault detection equipment for high speed railways; military and civil flight simulators; autopilots and low frequency vibration monitoring.

In addition to the instruments offered in this bulletin we design and develop accelerometers for specific applications. These custom designed units can be manufactured and tested to conform to specific requirements and standards, e.g. in automotive and military industry.

All AAA210 and AAA220 Series Accelerometers operate as a closed-loop torque balance servo system. With reference to the illustration below the pendulous mass 'A' develops a torque proportional to the product of its mass unbalance and the applied acceleration. The movement of mass 'A' is detected by position sensor 'B' whose output signal is connected to an amplifier. The resulting current is fed into the torquer motor 'C' which then develops a torque exactly equal to, but directly opposed to the initial torque from the pendulous mass 'A'. Mass 'A' stops moving, assuming a position minutely differing from it's zero 'g' position. Simultaneously, the current to the torquer motor is fed through a stable resistor to provide an output voltage proportional to the applied acceleration.

The system is damped by means of a phase advancing network within the integrated thick film module. The AAA210 and AAA220 series servo operation can be checked (self test) after installation by applying an independent current input to the torquer motor. By adjusting the parameters of the servo amplifier and related electronic networks, the operating characteristics of a servo accelerometer can be changed or modified to suit a particular application.

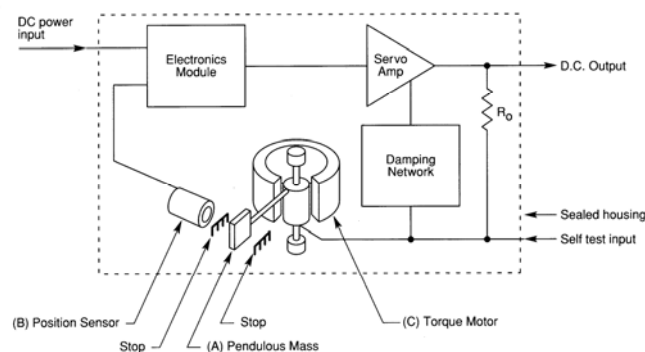

■ Specification

Designed for operation from a 15-0-15 DC power supply 2 versions are available. The AAA210 has a volume of approximately one cubic inch and is intended for use where space is limited. Electrical termination is via solder pins. The AAA220's larger size allows for solder pin or connector termination and optional features including bias, or low impedance outputs.

Input:	
Ranges	±1.0 g / ±2.0 g / ±5.0 g / ±10.0 g / ±20.0 g
Input Voltage	±15 V (±10 %) DC
Input Current	±15 mA max.

Range (g)	Natural Frequency (nom. Hz)	Output Impedance (kΩ)
±1.0	90	5
±2.0	100	2.5
±5.0	115	5
±10.0	130	2.5
±20.0	150	5

Output at 25 °C:	
Full Range Output	±5 VDC ±1 %
Zero Offset	≤±0.1 % FRO
Nonlinearity (LMS)	≤±0.05 % FRO (ranges to ±10 g), ≤±0.10 % FRO (range ±20 g)
Hysteresis	≤0.02 % FRO
Resolution	≤0.0005 % FRO
Cross Axis Sensitivity	≤±0.2 % FRO (ranges to ±10 g), ≤±0.5 % FRO (range ±20 g)
Noise Output	5 mV (RMS) max.
Damping Ratio	0.6 (±0.1)



AAA210

Environmental	
Temp. Operating	-55 °C to +95 °C
Temp. Storage	-65 °C to +105 °C
Thermal Sensitivity Shift	≤±0.02 % FRO/°C
Thermal Zero Shift	≤±0.002 % FRO/°C
Altitude	-45 to +35450 meters without damage
Shock	100 g for 11 ms (½ sine wave)
Acceleration	Will withstand constant 100 g in all 3 axes without damage
Humidity / Immersion	IP65
Insulation Resistance	≥20 MΩ at 50 VDC



AAA220

Physical	
Sensitive Axis Alignment	Parallel to fixing holes within ±0.2°
Weight	approx. 57 grams (AAA210), 115 grams (AAA220)

■ Dimensions

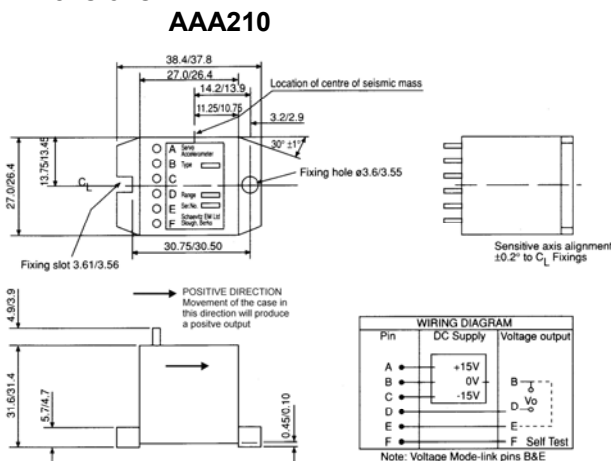

All dimensions mm, approx. values

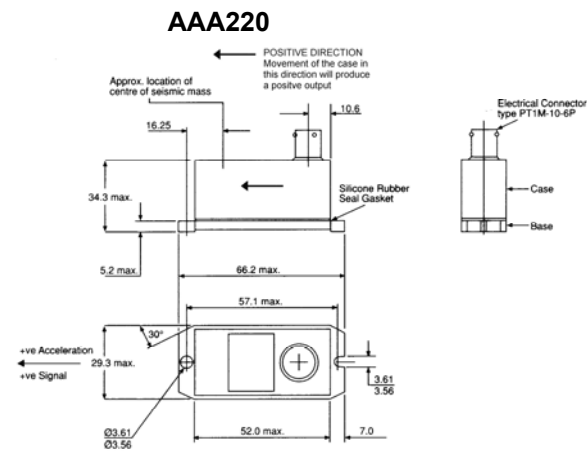

■ Designation and Ordering Information

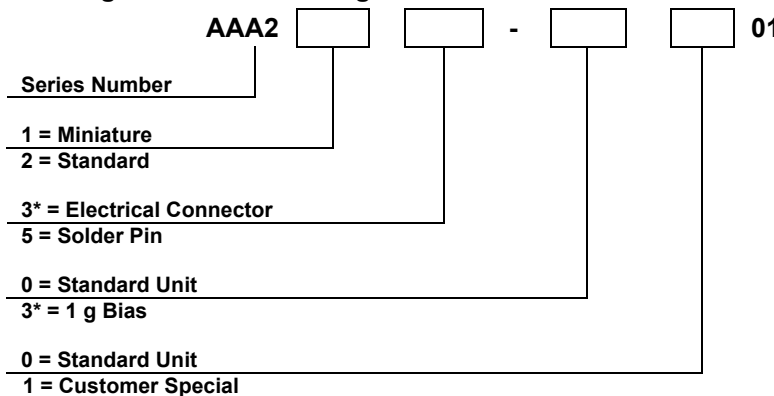

■ Electrical Connection

Pin A	+15 VDC excitation
Pin B	0 VDC excitation/output
Pin C	-15 VDC excitation
Pin D	±5 VDC output
Pin E	Not Connected
Pin F	Self Test

* not available for AAA210 series

Our policy is to improve specification of our products continuously, so technical and production details can be changed without any notice.