

# LBB Series Ultra-Precision Gage Heads

## Linear Ball Bearing Design

### Spring-Extend and Air-Extend

## DESCRIPTION

The **Linear Ball Bearing (LBB) series** of dimensional gaging probes is engineered for highly precise and repeatable measurements in quality control and metrology applications.

LBB within the gaging probe minimize radial play and friction for ultra-precise measurement. Bearing assemblies utilize two circumferential rows of miniature balls held in position by a retainer. the balls ride on a non-rotating plunger hardened to Rockwell 65, hard-chromed plated and precision ground for optimal repeatability and resistance to brinnelling. the contact end of the plunger has a removable tungsten carbide ball tip, with an AGD standard 4-48 UNF-2A threading.

Plunger and bearings are enclosed in a cylindrical housing, hand-honed and fit to the ball bearing assembly. Precision fitting provides for exceptional gage head repeatability. With the bearings and housing essentially matched in hardness, the plungers can better tolerate side loads for a longer unit life.

### LVDT Configuration

A Linear Variable Differential Transformer (LVDT) is contained in the opposite end of the tubular housing. With no physical contact between its core and coils, the LVDT produces a highly repeatable, low noise output voltage linearly proportional to probe displacement. Output can be sensed, amplified and displayed with any Measurement Specialties (Schaevitz) LVDT compatible signal conditioner, digital readout or LVDT computer based system.

LBB gage heads feature a unique two-piece construction. Units, therefore, are reparable should either probe structure or cables become damaged. A bend relief spring prevents cable damage at lead exit.

Positive mechanical stops prevent damage to the LVDT from severe impacts t the end of the contact tip in cases of overstroke.



## FEATURES

- ◆ AC-operated
- ◆ Linear Ball Bearing Assemblies
- ◆ Removable Tungstend Carbide Contact Tip for Long-term Reliability and Interchangeability
- ◆ Double-shielded LVDT for Greater Protection from Effects of Magnetic Materials
- ◆ Polyurethan-jacketed Cable Enhances Flexibility and Improves Chemical Resistance
- ◆ Standard Viton Boot for Greater Resistance to Chemicals and High Temperatures

## APPLICATIONS

- ◆ Point-of-Manufacture status of production process standards
- ◆ On-line Inspection of Automobile Bodies
- ◆ Process Feedback for Numerically-Controlled Machine Tools
- ◆ Automated Data Collection For Factory SPC
- ◆ Robotics

# LBB Series Ultra-Precision Gage Heads

## gage ranges

±0.020"	Spring-extend
±0.040"	Spring-extend
±0.100"	Air or Spring-extend
±0.200"	Spring-extend

## common specifications

<b>Input Frequency</b>	2.5 to 10 kHz
<b>Linearity</b>	< ±0.20% of full range output
<b>Repeatability</b>	0.000004" (0.10µm)
<b>Operating Temp. Range</b>	-45°F to 160°F(-40°C to 70°C)
<b>Temperature Coefficient of Sensitivity</b>	±0.005% of full range output/°F (±0.01% of full range output/°C)
<b>Housing Material</b>	High carbon, chromium heat treated tool steel
<b>Cable</b>	6.5 feet (2 meters), 32 AWG stranded, PTFE insulated, shielded polyurethane jacket, 6 conductor
<b>Cable Exit</b>	Axial standard; adaptor provided with most units allow for radial exit

## gaging methods

### Spring-Extend Gage Heads

Standard spring -extend LBB gage heads possess user-adjustable pretravel/overtravel settings. Units are available in both 3.15" (8 mm) and 0.375" (9.5 mm) diameters, with the latter available in both threaded and non-threaded housings. A 0.375" (9.5 mm) diameter, plain or threaded sleeve, can be provided for OEMS who want to stock one model with two diameters.

### Air-Extend, Spring-Retract Gage Heads

Air-extend, spring-retract units are manufactured in a ±0.100" (±2.5 mm) gaging range. These units require dry, oil-free air at 5 to 15 psi (0.34 to 1 bar). by varying air pressure, users can control gaging force to ensure the probe does not damage finely finished surfaces or distort delicate parts. Air extend models are available in 0.375" diameters with either threaded or non-threaded housings.

# LBB Series Gage Heads

±0.020 Range; Spring-Extend Design

## FEATURES

- ◆ Ultra-Precision Performance
- ◆ AC-Operated
- ◆ User-Adjustable Pretravel and Overtravel Settings
- ◆ 0.315" (8 mm) or 0.375" (9.5 mm) Body Diameter
- ◆ Plain or Threaded Housing
- ◆ Calibration Certificate Supplied with Every Gage Head
- ◆ Compatible with All Schaevitz® Signal Conditioners
- ◆ 4 Connector Options



## electrical specifications

Excitation	3.5 V rms at 5.0 kHz (nom)
Sensitivity	6.9 – 7.2 mV/V/.001"
Null Voltage	2.0 mV (max)
Phase Shift	6.5° ±3°
Primary Impedance	405 ohms
Secondary Impedance	1320 ohms

## mechanical specifications

Pretravel	0.002" to 0.005"
Overtravel	0.005" (min)
Probe Force	2.47 oz (70g) nominal at null
Body Diameter	0.315" or 0.375"
Body Type	Plain or threaded
Cable Length	6.5' (2.0m)
Tip Thread	2.5 mm

## wiring

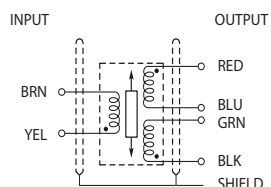

Note:  
BLU and GRN tied for differential output with YEL and BLK common. The output is in phase, with core displaced toward cable end. (Retract)

## dimensions

in (mm)

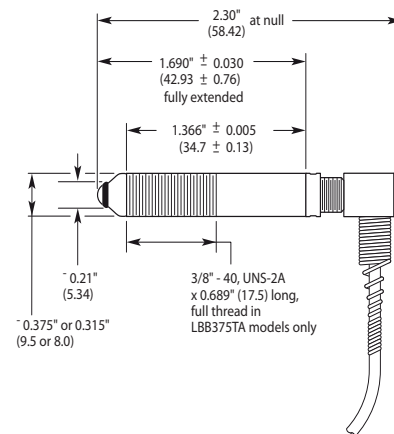

## ordering information

Specify the appropriate model number followed by the desired connector number. For example: LBB375PA-020-1.

Model Number	Body Diameter	Housing
LBB315PA-020	0.315"	Unthreaded
LBB375PA-020	0.375"	Unthreaded
LBB375TA-020	0.375"	Threaded

# LBB Series Gage Heads

±0.040 Range; Spring-Extend Design

## FEATURES

- ◆ Ultra-Precision Performance
- ◆ AC-Operated
- ◆ User-Adjustable Pretravel and Overtravel Settings
- ◆ 0.315" (8 mm) or 0.375" (9.5 mm) Body Diameter
- ◆ Plain or Threaded Housing
- ◆ Calibration Certificate Supplied with Every Gage Head
- ◆ Compatible with All Schaevitz® Signal Conditioners
- ◆ 4 Connector Options
- ◆ Special Contact Tips



## electrical specifications

Excitation	3.5 V rms at 5.0 kHz (nom)
Sensitivity	5.0 – 5.5 mV/V/0.001"
Null Voltage	5.0 mV (max)
Phase Shift	3.0° ±3°
Primary Impedance	960 ohms
Secondary Impedance	2150 ohms

## mechanical specifications

Pretravel	0.002" to 0.005"
Overtravel	0.005" (min)
Probe Force	2.47 oz (70g) nominal at null
Body Diameter	0.315" or 0.375"
Body Type	Plain or threaded
Cable Length	6.5' (2.0m)
Tip Thread	4-48 AGD

## wiring

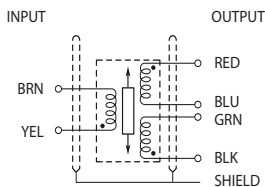

Note:  
BLU and GRN tied for differential output with YEL and BLK common.  
The output is in phase, with core displaced toward cable end. (Retract)

## dimensions

in (mm)

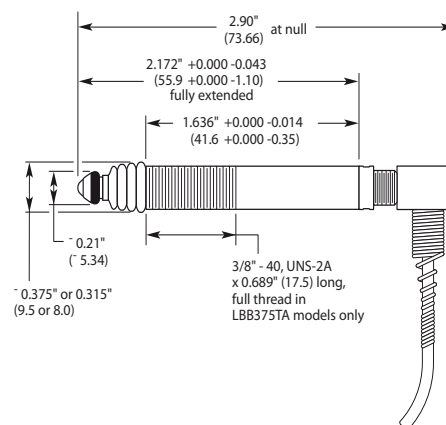

## ordering information

Specify the appropriate model number followed by the desired connector number. For example: LBB315PA-040-1. Special contact tips are also available and can be ordered separately.

Model Number	Body Diameter	Housing
LBB315PA-040	0.315"	Unthreaded
LBB375PA-040	0.375"	Unthreaded
LBB375TA-040	0.375"	Threaded

# LBB Series Gage Heads

±0.100 Range; Spring-Extend Design

## FEATURES

- ◆ Ultra-Precision Performance
- ◆ AC-Operated
- ◆ User-Adjustable Pretravel and Overtravel Settings
- ◆ 0.315" (8 mm) or 0.375" (9.5 mm) Body Diameter
- ◆ Plain or Threaded Housing
- ◆ Calibration Certificate Supplied with Every Gage Head
- ◆ Compatible with All Schaevitz® Signal Conditioners
- ◆ 4 Connector Options
- ◆ Special Contact Tips



## electrical specifications

Excitation	3.5 V rms at 5.0 kHz (nom)
Sensitivity	5.0 – 5.5 mV/mV/0.001"
Null Voltage	5.0 mV (max)
Phase Shift	3.0° ±3°
Primary Impedance	960 ohms
Secondary Impedance	2150 ohms

## mechanical specifications

Pretravel	0.002" to 0.005"
Overtravel	0.005" (min)
Probe Force	2.47 oz (70g) nominal at null
Body Diameter	0.315" or 0.375"
Body Type	Plain or threaded
Cable Length	6.5' (2.0m)
Tip Thread	4-48 AGD

## wiring

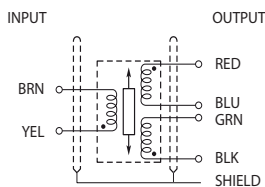

Note:  
BLU and GRN tied for differential output with YEL and BLK common. The output is in phase, with core displaced toward cable end. (Retract)

## dimensions

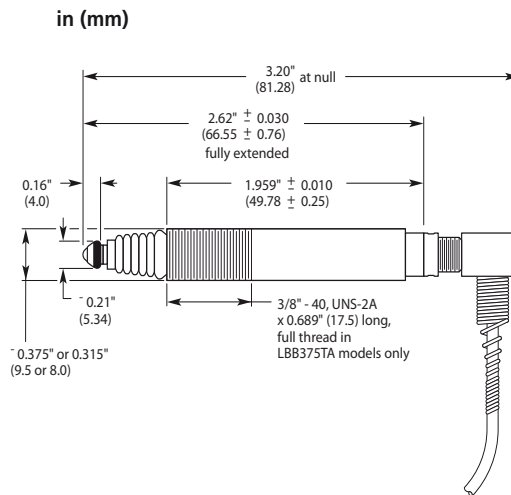

## ordering information

Specify the appropriate model number followed by the desired connector number. For example: LBB375PA-100-1. Special contact tips are also available and can be ordered separately.

Model Number	Body Diameter	Housing
LBB315PA-100	0.315"	Unthreaded
LBB375PA-100	0.375"	Unthreaded
LBB375TA-100	0.375"	Threaded

# LBB Series Gage Heads

±0.100 Range; Air-Extend Design

## FEATURES

- ◆ Ultra-Precision Performance
- ◆ AC-Operated
- ◆ 0.375" (9.5 mm) Plain or Threaded Housing
- ◆ Variable Probe Force
- ◆ Calibration Certificate Supplied with Every Gage Head
- ◆ Compatible with All Schaevitz® Signal Conditioners
- ◆ 4 Connector Options
- ◆ Special Contact Tips



## electrical specifications

Excitation	3.5 V rms at 5.0 kHz (nom)
Sensitivity	5.0 mV (max)
Phase Shift	±20°
Primary Impedance	260 ohms
Secondary Impedance	215 ohms

## mechanical specifications

Pretravel	0.005"
Overtravel	0.110" (min)
Probe Force	Variable
Body Diameter	0.375"
Body Type	Plain or threaded
Cable Length	6.5' (2.0m)
Tip Thread	4-48 AGD

## wiring

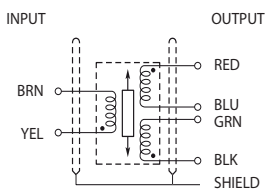

Note:  
BLU and GRN tied for differential output with YEL and BLK common. The output is in phase, with core displaced toward cable end. (Retract)

## dimensions

in (mm)

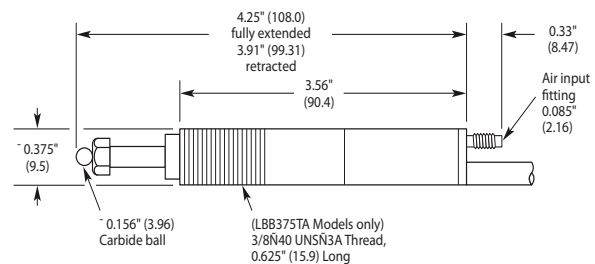

## ordering information

Specify the appropriate model number followed by the desired connector number. For example: LBB375PA-100A-1. Special contact tips are also available and can be ordered separately.

Model Number	Body Diameter	Housing
LBB375PA-100A	0.375"	Unthreaded
LBB375TA-100A	0.375"	Threaded

# LBB Series Gage Heads

±0.200 Range; Spring-Extend Design

## FEATURES

- ◆ Ultra-Precision Performance
- ◆ AC-Operated
- ◆ 0.315" (8 mm) Body Diameter
- ◆ Plain Housing
- ◆ Calibration Certificate Supplied with Every Gage Head
- ◆ Compatible with All Schaevitz® Signal Conditioners
- ◆ 4 Connector Options



## electrical specifications

Excitation	5 V rms at 5.0 kHz (nom)
Sensitivity	4.3 mV/V/.001"
Null Voltage	5.0 mV (max)
Primary Impedance	258 Ω
Secondary Impedance	711 Ω
Phase Shift	5.3° (at 5 kHz)

## wiring

Wiring Schematic

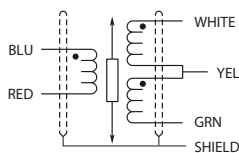

## mechanical specifications

Pretravel	0.005"
Overtravel	0.045" (min)
Probe Force	4.4 oz (125g) nominal at null
Body Diameter	0.315"
Body Type	Plain
Cable Length	6.5' (2.0m)
Tip Thread	2.5 mm

## dimensions

in (mm)

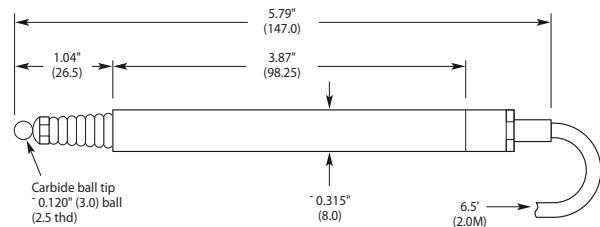

## ordering information

Specify the appropriate model number followed by the desired connector number (from page 100). For example: LBB315PA-200-1.

<b>Model Number</b>	<b>Body Diameter</b>	<b>Housing</b>
LBB315PA-200	0.315"	Unthreaded

We reserve the right to vary the foregoing details without prior notice



**ALTHEN GmbH Mess- und Sensortechnik**

Frankfurter Strasse 150 - 152  
65779 Kelkheim / Germany

phone: +49 (0)6195 70060  
fax: +49 (0)6195 700666

sales@althensensors.com  
www.althensensors.com